

# WaterCop®

by DynaQuip

Emergency Leak Detection and  
Water Shut-off System

## Owner's Manual / Installation Guide

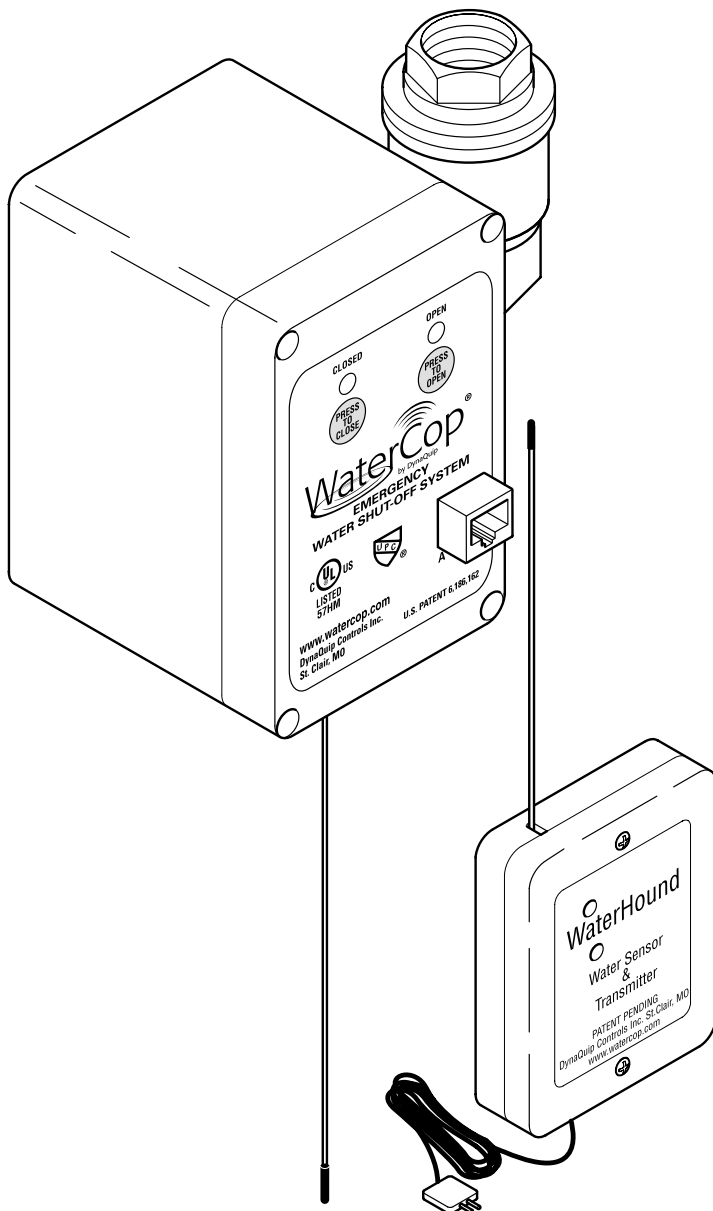

### System Description

The WaterCop® System is designed to detect leaks in your plumbing system at predetermined locations, and automatically shut off the water supply to help effectively reduce the chances of major water damage associated with a leak.

### System Components

The WaterCop® System is composed of two basic parts:

- The WaterCop® - A motorized ball valve that houses a wireless radio receiver which automatically turns off your water supply when the WaterHound detects water.
- The WaterHound - A moisture sensor which houses a wireless radio transmitter which detects water from a leak or overflow and sends a signal to the WaterCop® to turn off your water supply.

### General Safety Information

#### Warning

Do not apply electrical power to the unit unless the unit is fully assembled (as it shipped). Failure to do so could result in personal injury and/or damage to the unit.

#### Warning

Disconnect power source before working on or servicing the unit. Failure to do so could result in personal injury.

#### Caution

It is strongly recommended that eye protection be worn while servicing the system. Failure to do so could result in personal injury.

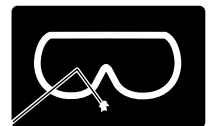

### How the System Works

The WaterHounds constantly monitor their selected areas for accumulating moisture. When a leak is detected, a WaterHound will send a radio frequency signal to the WaterCop® unit instructing it to shut off the water supply to the home. The WaterCop® valve will remain closed until it is manually reset.

The WaterHound is a battery powered device enabling

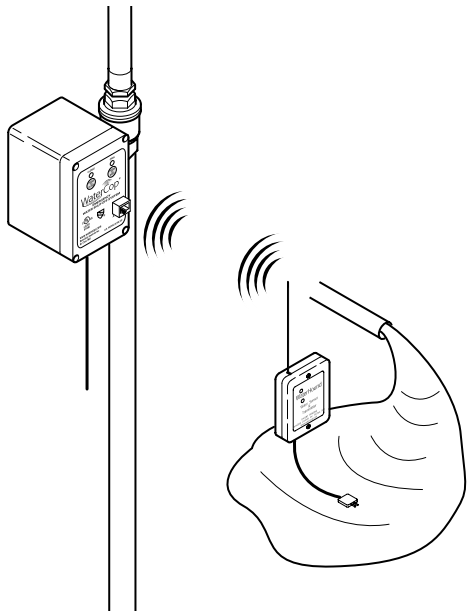

it to be located anywhere a leak is likely to occur, or where water might cause damage. The WaterCop® requires household electrical power (common 115 VAC, grounded outlet) and will not operate during a power outage.

### Selection of WaterCop® Installation Sites

The WaterCop® valve should be installed in the main water line just downstream from the main shut-off valve in your home. The **front control panel** of the WaterCop® should be easily visible in order to see what position the valve is in (open/closed). It should also be easily accessible for resetting after a leak has been detected and the water supply has been shut off. While the WaterCop® is completely supported by the piping in your plumbing system when it is installed, placement of the valve should ensure that the housing is protected from use as a step or from other excessive loads. The WaterCop® requires household electrical power, and the provided power cord must be plugged into a properly grounded power source (115 VAC). Do not use an extension cord.

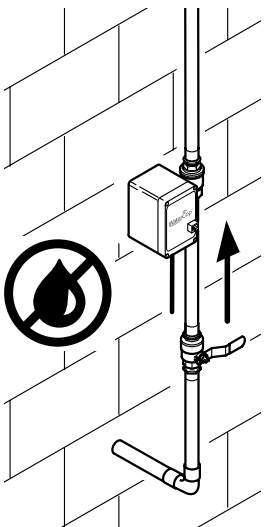

The shut-off valve must be installed indoors

- In the main water line;
- Just downstream from the main water shut-off valve;
- In a dry location;
- Where it is accessible for checking and resetting the valve and for resetting the radio receiver code, if necessary;
- Where the case is protected from use as a step or from other excessive loads.

**Local electrical and plumbing codes should be consulted to ensure that the installation is in complete compliance. (See Installation section for details.)**

### Selection of WaterHound Locations

Each WaterCop® can support an unlimited number of WaterHounds. Additional WaterHounds may be added at any time. A WaterHound consists of a transmitter (a rectangular box with an antenna) and a sensor (a small disc at the end of the wire, with two short gold prongs protruding from one side). The WaterHound should be placed in locations where leaks are most likely to occur.

The transmitter in the WaterHound and receiver in WaterCop® communicate by radio frequency. The smaller the distance between them, the stronger the signal will be. The maximum transmission distance is somewhat dependent upon the building layout and type of construction, but will be in the 150'-200' range. The WaterHound transmitter (attached to the sensor) must be kept dry. It is NOT splash proof. The WaterHound should never be placed outdoors. The sensor detects the water from a leak and is completely waterproof. Sensors should be placed on the floor or in areas where water would tend to accumulate rapidly in common leak or overflow situations. **Make sure that any water from a leak will drain toward the sensor, not away from it.** Avoid high traffic areas where the cord or sensor could be stepped on or kicked and where children or pets may disturb it. **The sensor should be placed FLAT on the floor so water can be detected as soon as it begins to accumulate.** The sensor may be secured to the floor with adhesive tape. To avoid damage to transmitters and to provide for the strongest signal possible, the WaterHound transmitter should be mounted in a convenient location (on the wall, in a cabinet, closet, etc.) two to three feet above the floor (see illustration on page 4). (See Installation section for details on WaterHound installation.)

### Suggested Locations

- |                  |                                  |
|------------------|----------------------------------|
| Washing Machines | Toilets                          |
| Dishwashers      | Icemakers/Refrigerators          |
| Kitchen Sinks    | Automatic Humidifiers            |
| Bathroom Sinks   | Pipes that are prone to freezing |
| Water Heaters    |                                  |

### WaterHound Battery Life

High quality alkaline "AA" batteries are recommended. Under normal conditions (standby mode) the batteries should last about one year. Each transmitter has a low battery signal (audible chirp). Replace batteries at least annually or when low battery signal is detected. Re-test each unit in its regular location (see installation manual). If you are away from home for long periods of time, transmitters should be tested upon your return to ensure proper function.

### Operating the WaterCop® System

The normal position of the valve is open to allow full flow throughout the plumbing system. WaterCop® is a full port ball valve which does not restrict the flow capacity of your plumbing system. The indicator lights on the face of the WaterCop® will show the position of the valve.

If the valve is in the closed position (the red light will be lit), press "open" and the valve will move to the open position (green indicator will light).

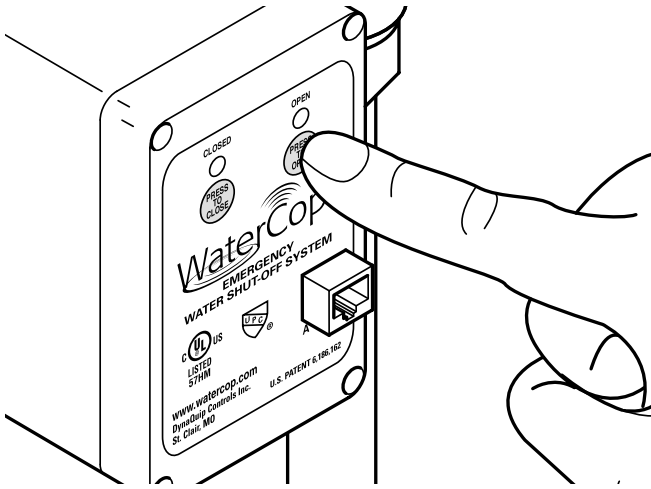

When water comes in direct contact with a WaterHound sensor, an RF (radio frequency) signal is transmitted to the WaterCop® and the valve closes, turning off the water source to protect the building from additional water damage. The red indicator light will signal that the valve is now in the closed position, and that you need to check all areas where you have placed a WaterHound to determine what plumbing product caused the system to activate. The valve will remain closed until the unit is reset on the WaterCop® panel. After the plumbing problem is fixed, reset the WaterCop® by pressing "open valve" (green circle) on the face of the WaterCop®. Valve will open and green indicator will be lit. See illustration to the lower left.

Note: If major repairs are needed to correct the plumbing system, it is recommended that the manual shut-off valve upstream of the WaterCop® also be closed during the repairs. Close the main water shut-off valve and unplug the WaterCop® before doing repairs on the plumbing system.

Note: In case of a power failure, the WaterCop® cannot operate. If the power is out, you will need to use the manual shut-off valve to turn the water off in case of an emergency. When power is restored, the WaterCop® will remain in its last known position indicated by the red or green lights on the face of the unit.

### WaterCop® Specifications

Max. working pressure ...125 PSIG  
 Ambient temperature .....35° to 105° F  
 Enclosure .....Polycarbonate  
 Voltage .....115, 1 Phase, 60 Hz  
 Current .....2.5 Amps  
 Power Input:  
 Standby .....1.375 W  
 Holding (2.5 sec) .....75 W  
 Power Cord .....8 ft. Heavy-Duty Grounded  
 Valve .....Full-Port, Brass, NPT  
 Valve Seals .....RTFE

### Flow Data

Valve Size Cv = Gpm flow @ 1 PSI pressure drop  
 1/2" NPT 19  
 3/4" NPT 34  
 1" NPT 52  
 For cold water applications.

### FCC Information

This equipment has been tested and found to comply within limits of a class B digital device, pursuant to part 15 of the FCC Rules. These limits are designed to provide reasonable protection against harmful interference in a residential installation. This equipment generates, uses, and can radiate radio frequency energy and if not installed and used in accordance with the instructions, may cause harmful interference to radio communications. However, there is no guarantee that interference will not occur in a particular installation.

The water sensors only transmit a radio signal during testing and when contact is made between the probes as when water is detected. This signal is of a 2-second duration and is repeated approximately every 6 seconds while activated. This 2 second signal should be the only time potential interference could be detected. If you suspect the unit is interfering with your radio and/or television reception on a prolonged basis, remove batteries from all transmitters to determine if this unit is causing the interference. If so, please consult your dealer.

### LIMITED WARRANTY

DynaQuip Controls Corporation warrants the WaterCop® to be free from defects in material and workmanship under normal use and if properly installed for a period of three years from the date of purchase. If found to be defective as mentioned above, it will be replaced or repaired if returned prepaid along with proof of date of purchase. This shall constitute the sole remedy of the purchaser and the sole liability of DynaQuip Controls Corporation. To the extent permitted by law, the foregoing is exclusive and in lieu of all other warranties or representations whether expressed or implied, including any implied warranty of merchantability or fitness. In no event shall DynaQuip Controls Corporation be liable for special or consequential damages.

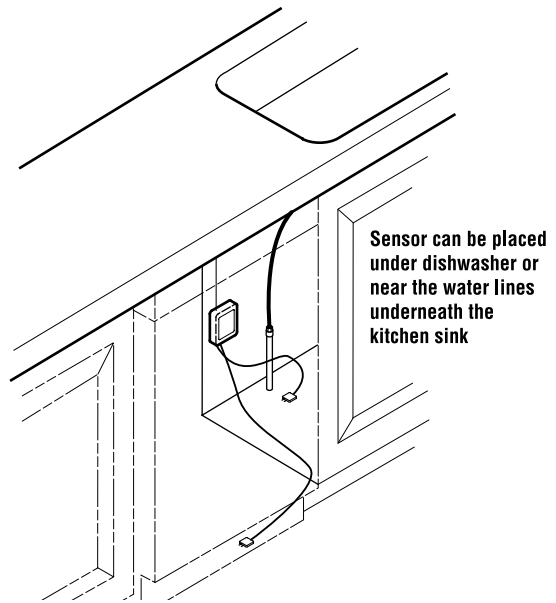
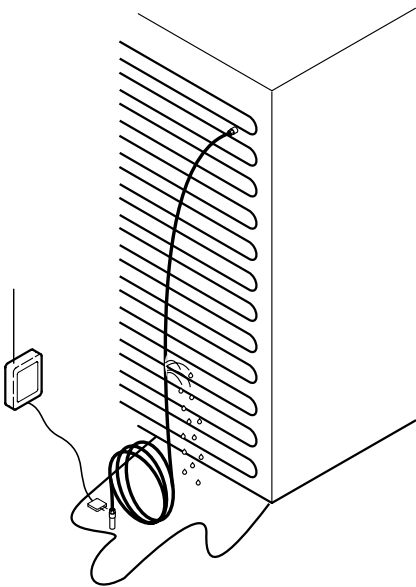
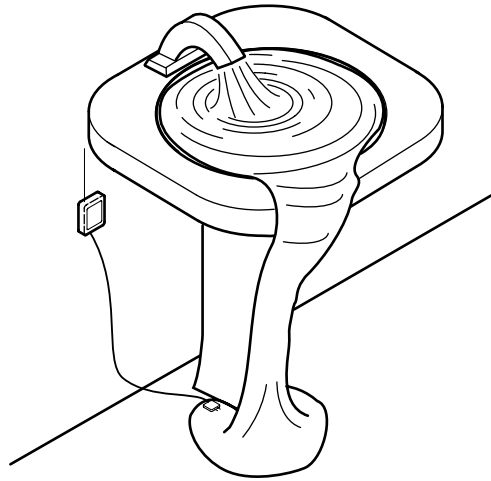
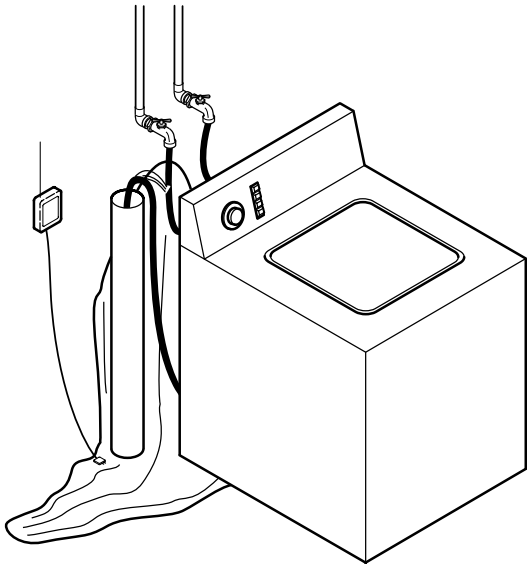
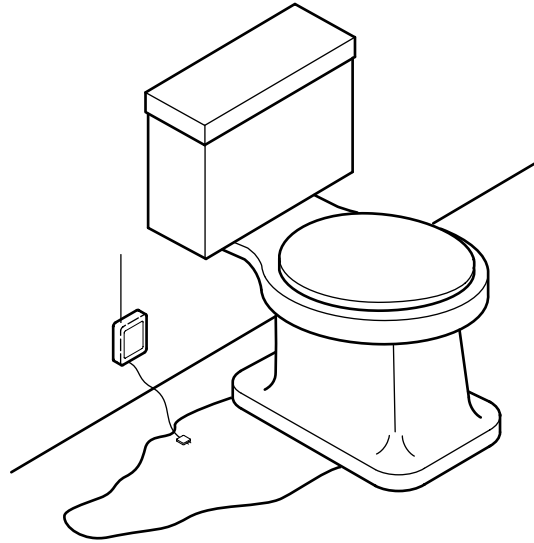
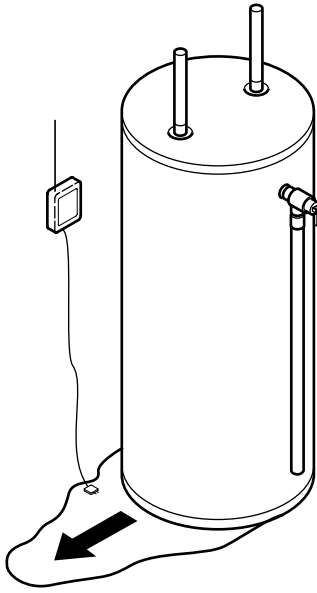

# Installation Guide

## Important!

Adherence to all local and municipal building, plumbing and electrical codes as they pertain to the installation of the WaterCop® System is of utmost importance. Codes in some areas may require that a licensed plumber be employed to do the installation, or that the proper permits be obtained prior to any installation. Even if local codes do not require a licensed plumber to do the installation, it is necessary that the installer has a professional level of competence in both plumbing and electrical skills to perform the installation. These instructions assume this level of knowledge and skill. If in doubt, use a licensed professional.

## Pre-installation Testing of WaterCop®

Although each unit is pre-tested at the factory, it is highly recommended that the unit be tested prior to installation to ensure proper operation in your home. Operating the valve before connecting to the water line will not damage it. But be careful!

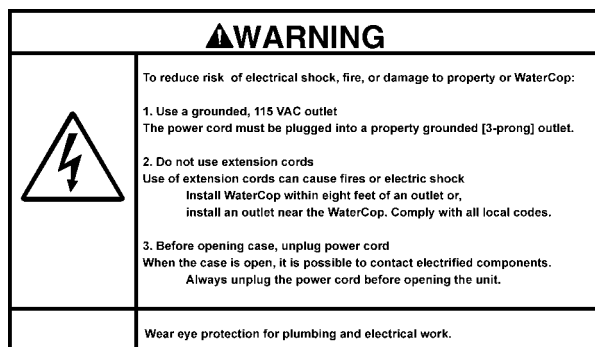
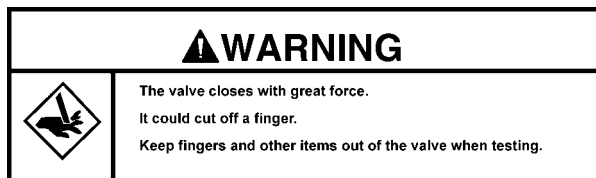
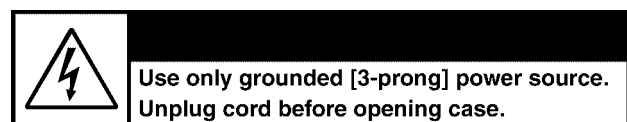

- The valve closes with enough force to cut off a finger.
- Be extremely careful to keep fingers and other items out of the valve.
- Always use a grounded (3-prong) electrical outlet.

## Manually Test the Valve

To test your WaterCop® system, gently pull the safety plugs out from each end of the valve. Check the position of the valve by looking in either threaded end. In the open position, you will be able to see through the valve; in the closed position only the shiny surface of the ball will be visible. Place the base of the housing on a sturdy surface, as close as feasibly possible to the

location where it will be permanently installed. Plug the WaterCop® power cord into a nearby grounded 115 VAC outlet. The valve position indicator lights should now correspond to the actual position you noticed. Green = Open. Red = Closed. Grasp both sides of the housing (not the valve) with the valve pointing away from you for safety. Being very careful not to have your fingers or other objects near the valve openings, press the colored circle just below the unlit indicator light. You will hear the motor change the valve position. Again, look into the threaded end of the valve to verify that the valve has changed position. **If it appears that the valve has not turned from one position to the other, DO NOT try to reposition the valve yourself by inserting any tool or fingers into the valve.** Operate the valve several more times from open to close, checking each time for proper positioning. If you are experiencing trouble getting the valve to open and shut, call the installation help line listed on the back cover.

## Manually Test the WaterHounds

Each WaterHound is a battery-operated radio transmitter. The units are shipped without batteries. Two fresh "AA" alkaline batteries are needed to power each unit. To install batteries, remove the battery cover retaining screws and cover located on the front of the WaterHound, and install batteries in accordance with the (+ and -) placement guide. Reinstall cover and screws.

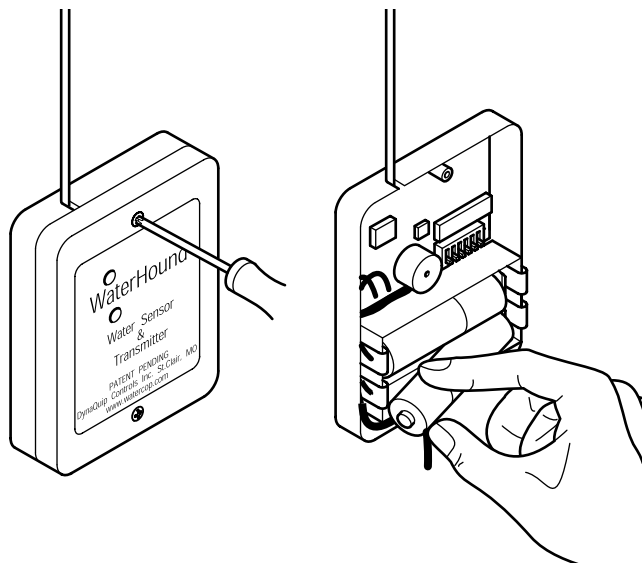

Follow suggestions found in the section titled "Selection of WaterHound Locations" for recommendations where WaterHounds should be placed. Locate a wall near the area you choose to monitor. Avoid high traffic areas where cord or sensor could be stepped on or kicked. Mount transmitter at a convenient location on the wall, two to three feet above the floor. This will help avoid damage to the WaterHound and provide a strong signal. Use hook and loop fastener included with the unit.

1. Following all safety precautions, make sure that the WaterCop® is plugged in and the valve is in the

## Manually Test the WaterHounds (Continued)

- open position. Leave the WaterCop® near your main water line, on a sturdy surface. It is important that anyone who will be near the valve is aware of the safety precautions, and does not insert any object into the valve, or handle the valve during the test.
2. At one of the locations you have chosen to monitor, drop the sensor (not the mounted transmitter) into a cup of water. Hold until you hear the WaterHound transmit a signal to the WaterCop® (about 5 seconds). The signal will be a series of short beeps followed by a long tone. This test simulates a leak, and ensures that there is no interference between the WaterHound and the WaterCop®.
  3. Take the sensor out of the water and carefully dry off the sensor and prongs.
  4. Go back to your WaterCop® and verify that the valve has closed (the red indicator light will be lit).
  5. Keeping all objects away from the valve, reset the WaterCop® by pushing the green circle below the "Valve Open" text.
  6. Repeat steps 2 through 5 until you have tested each WaterHound directly in the locations you wish to monitor.

## Troubleshooting

- If the WaterHound transmitter does not close the valve, check that the batteries are good and that they are installed properly. Repeat test.
- If the batteries are good and the WaterHound

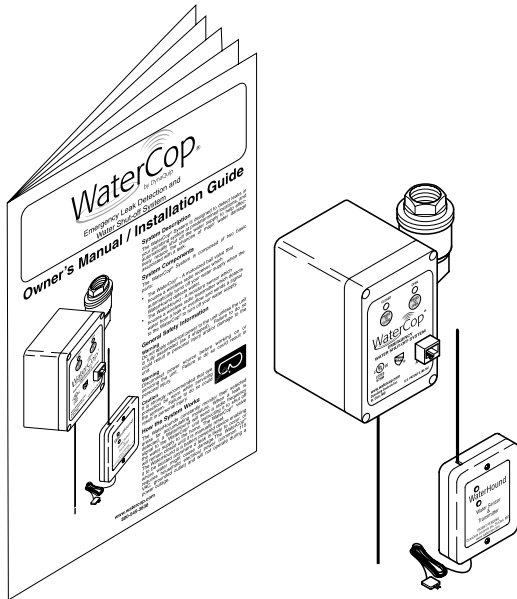

transmitter still does not make the valve close, remove it from its installed location and place it close to the valve. Repeat test.

- If the WaterHound operates properly when it is close to the WaterCop® valve, but not when it is installed at its remote location, try moving the transmitter to a different position or try a different WaterHound.
- If the unit still does not function properly, check the digital code settings (see instructions for changing digital codes).
- If the code matches the code on the WaterCop valve, and it still does not function properly, replace the WaterHound.

## WaterHounds Installation

Once testing is complete, finish installation of the WaterHounds by unwinding the cord and placing the sensor on the floor at the lowest point (where water would naturally collect) in the area to be monitored. **Be sure that the sensor is placed FLAT on the floor so water can be detected as soon as it begins to accumulate.** The sensor may be secured to the floor with adhesive tape, taking care that the metal probes are not covered. Verify that the transmitter and wire are clear of doors, drawers, sharp edges, or other hazards that may cause damage.

**Sensor placed at a low spot in the path of water flow where it will make contact with sensor.**

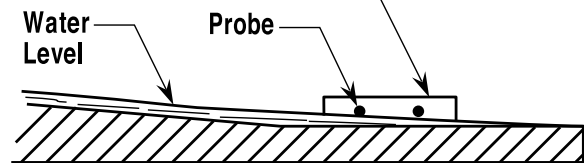

**Unplug the WaterCop® after the testing is complete. The WaterCop® can now be installed. Prior to installation, read all warnings and precautions carefully.**

## Installation Procedure

Check the contents of the carton with the products listed on the carton label. The shipping package should contain the following:

- 1 ea. WaterCop® with 8 ft. electrical power cord
- 1 ea. Owner's Manual/Installation Guide

Note: The package may contain WaterHounds if purchased as part of kit.

Read Operating Instructions before any installation is attempted. All sections of this Installation Guide and accompanying Owner's Manual should be read and completely understood.

## Review Location and Type of Main Supply Line

The main supply line should enter the house in either the basement or a crawl space beneath the first floor. The water main shut-off valve is usually located near where the line comes through the basement wall or just after the water line enters the living area from the crawl space. In apartments, townhouses, and manufactured housing constructions the water main shut-off valve can usually be found in close proximity to the water heater installation. The WaterCop® valve should be installed in the main water line just downstream from the main shut-off valve in your home. The water supply must be shut off prior to installation of the WaterCop®. If your home does not have a main shut-off valve, you must request that your water be temporarily shut off by your water supplier. Installing a shut-off valve at the same time as the WaterCop® should be considered.

Choose a dry location to install the WaterCop®. The front control panel should be easily visible in order to see what position the valve is in (open/closed) and accessible for resetting after a leak has been detected

and corrected, and for checking and resetting the radio receiver code if necessary. Place the valve where the housing is protected from use as a step or other excessive loads. The shut-off valve must be installed:

- In the main water line;
- Just downstream from the main water shut-off valve;
- In a dry location (indoors only);
- Where it is accessible for checking and resetting the valve and for resetting the radio receiver code, if necessary; and
- Where the case is protected from use as a step or other excessive loads.

**Caution: Never use the housing for leverage when mounting this unit or tightening fittings. Use a wrench on the valve flats that are provided.**

**Caution: High heat from soldering or brazing can damage valve seats or motor housing. Proper precautions should be taken to prevent damage from heat when installing the unit. Remove plastic housing before soldering valve in place.**

### Additional Part Requirements

Installation of the WaterCop® will require additional parts. When the main supply line is cut to accommodate the WaterCop®, new fittings will be needed to connect the ends of the piping to the WaterCop® valve.

The type of connecting fittings to use will be determined by the type of existing piping, local plumbing codes, and "industry standard practices."

The most common material for water supply lines is copper. If the WaterCop® is to be installed in a copper line, you still have a choice of fittings and methods of installation.

#### Compression fittings:

The unit can be installed with compression fittings using common household tools and basic mechanical ability. You will need:

- a) 2 fittings (male pipe thread x compression) available at most local hardware or plumbing supply stores
- b) Teflon tape or other thread sealant
- c) Tubing cutter
- d) Ruler
- e) Pencil or marker
- f) 2 large adjustable wrenches

Measure the outside diameter of the copper tube and note the valve size to be sure you purchase the proper size fittings for the job.

1. Remove nuts and sleeves from compression fittings and install the fittings into each end of the valve using Teflon tape or other thread sealant to ensure a watertight seal. Hold one wrench on flats of valve body and use the other to tighten fittings.
2. Measure the distance from end to end of valve assembly. For 1/2" tube (5/8 outside diameter) subtract 1/2", for 3/4" tube (7/8 outside diameter) subtract 3/4" from your measurement. This is the length of the section of tubing to be cut out of the existing line. The piece of existing tubing to be cut out is shorter than the measured length so that tube ends extend into the compression fittings.
3. Select the location for the WaterCop®. Be sure to consider that you will need access to the front

panel of the control unit. After cutting the section of tube out of the line, you will need to shift the tube ends to be able to fit the unit into place. Make sure you will have access and room to adjust before you cut the tube.

4. Mark the tube in the location you have selected. Double check the length and location you marked.
5. Turn water off and drain the system.
6. Use tube cutter to cut copper tube at the locations you marked. Careful, there will probably still be some water in the line.
7. Remove any burrs from the tube ends and clean ends.
8. Install compression nuts and sleeves to each tube end.
9. Shift tube ends to install WaterCop® valve in line.
10. Position the unit and tighten compression nuts. Hold the fitting with one wrench while tightening the nut with the other. Tighten both nuts.
11. Plug unit into a proper power source and turn valve to open position (open button / green light).
12. Unplug unit, turn water back on and carefully check for leaks.
13. Tighten fittings if needed to stop any leaks.
14. Plug unit back into power source. Installation is complete.

#### Solder fittings:

An alternative method is to solder the unit into the water line. This method requires a considerably higher skill level to accomplish the installation properly and safely. If you are not skilled in this area, it is strongly recommended that you contact a professional plumber to do this type of installation.

Each WaterHound (transmitter) will also require 2 "AA" alkaline batteries (not included).

### Electrical Connection

The WaterCop® is supplied with an eight foot (8 ft.) power cord and standard grounded 3 prong connector to be plugged into a properly grounded 115 VAC power source. Consult local electrical codes as to the necessity of ground fault protection. It is recommended that the WaterCop® not be plugged into an extension cord. Review "Specification" current and power requirements as not to overload the circuit supplying power.

### Warnings and Precautions

#### WARNING

The motorized drive unit case is not capable of supporting any loads. Do not attempt to use the unit as a step. This will cause damage to the unit and could cause personal injury. Do not store highly flammable items such as oily rags or other combustibles near your WaterCop®.

#### CAUTION

It is recommended that eye protection be worn while installing or servicing the system. Failure to do so could result in personal injury.

#### CAUTION

Do not use the case as leverage when mounting this unit or tightening fittings. Apply wrench to flats on the valve body to tighten fittings.

## Changing Digital Codes

Codes on all control units and transmitters are set at the factory and should not require alteration. If you use other wireless products in your home (garage door openers, etc.), there is a slight chance of interference with the signal. The following instructions will aid in resetting the code.

**Important Note: All transmitters and the control unit must have the same code setting!**

### Changing the receiver code

Disconnect power to receiver unit by unplugging power cord.

1. Remove cover using the 4 screws located in the corners of the cover.
2. Locate code switch block (see illustration at right). Switches are numbered 1 through 6.
3. Arrange the switches in any combination (on or off position). Write down the code combination you selected. Example: 1-on, 2-off, 3-off, 4-on, 5-off and 6-on.
4. Reinstall cover. Carefully tuck wires completely into case and hold cover in position while tightening screws.
5. Reconnect power by plugging the power cord into power receptacle.

### Changing the transmitter code

1. Remove transmitter cover (loosen two screws).
2. Locate code switch block. Switches are numbered 1 through 6.
3. Arrange the switches in the exact combination as the code that you set in the receiver. It is important that the same exact code be set in the receiver and all transmitters. If the codes differ, the unit will not function properly.
4. Reinstall cover. Repeat this procedure for all transmitters.
5. Test each transmitter to ensure that the unit is functioning properly.
6. If not, verify that all codes are set the same. When all transmitters are functioning properly, your WaterCop® system is on duty to help protect your home from damage due to plumbing leaks.

## WaterCop® Interface Connections

Contacts 5, 6 & 7 are used to control the valve position from a remote location. The most common is your home security system control panel.

This is done by wiring these contacts to a control switch on the panel. The diagram at right shows typical installation options. This control can be a relay, push buttons or toggle type switch. This control needs to be a momentary switch which means that the control switch stays made or 'on' for a short period of time (1 to 3 seconds) and then returns to a neutral position.

Contacts 2, 3 & 4 are used to signal a remote device as to the position of the valve. This is done by connecting a low voltage circuit with indicator lights to these contacts. The diagram shows a typical installation.

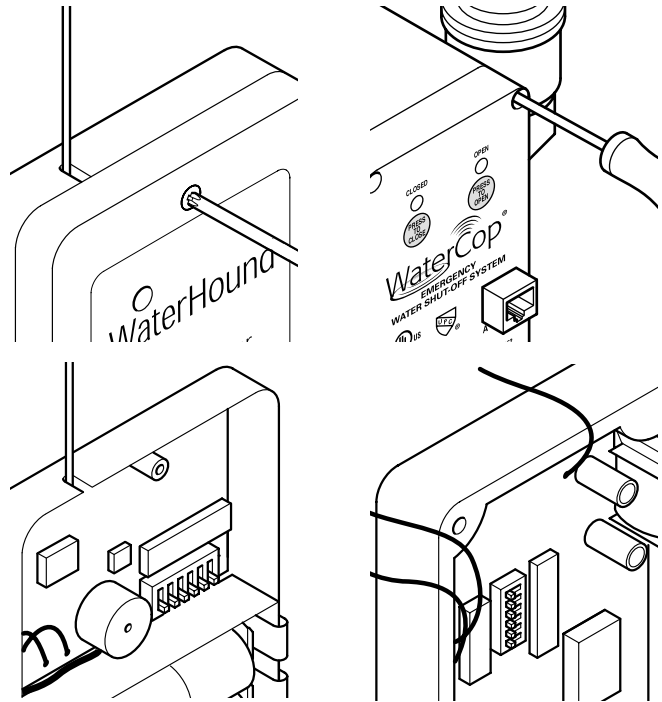

When the valve is in the open position contacts 2 & 3 will be made completing the circuit and lighting the indicator light, showing that the valve is in the normal open position.

When the valve is in the closed position, contacts 3 & 4 will be made completing the circuit and lighting the indicator light, showing that the valve is closed.

## Emergency Procedures

In the unlikely event that the WaterCop® System should shut off the main water supply and then become inoperable due to a power outage or damage, it is possible to manually operate the WaterCop® to return water service. Unplug the WaterCop® from its power source. The valve may be manually opened by removing the four screws holding the housing to the valve, sliding the housing off the valve shaft, and turning the valve shaft a quarter turn with a screwdriver. This procedure should only be necessary in emergencies.

